

Revision Date: May 2014

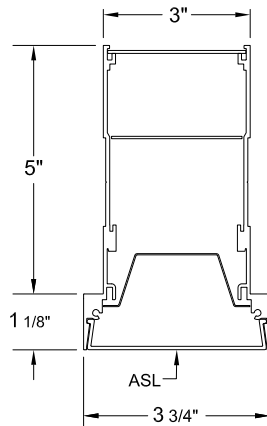

Click or scan QR code to view latest spec sheet.



**Fluorescent Lamping**



Click photo to view product page

- Page 2 Specifications
- Page 3 Photometric / Revit files / Lens Images
- Page 4 Mounting Details
- Page 5 Standard Colors / Finishes

Gammalux Lighting Systems reserves the right to change details of fixture designs and construction at any time.

**Product Overview** (for complete specifications, see page 2)

**Construction:** Extruded aluminum housing is available in lengths up to 24'. Continuous runs have hairline joints with no light leak. Runs of fixtures can be built to lengths matching field conditions. Housing is designed for integration with Hunter Douglas Techstyle or Echelon ceiling system.

**Electrical:** Gammalux products are **UL** and **cUL** listed with quick electrical connectors and ballasts by OSRAM SYLVANIA or equal. Runs of fixtures are tested as a complete system prior to shipping.

**Lamp Stagger:** Fluorescent lamps can be staggered for consistent illumination in continuous runs with no dark ends. ASLMD or ASLHD lens is recommended.

**Optical:** Reflectors are formed to provide even washing of light across the lens. Lenses available in standard, medium and heavy diffusion. See images on page 3.

**Finish/Color:** High quality paint finish in high gloss or semi-gloss. Custom colors available.

**Packing and Shipping:** Our packing, labeling and shipping systems ensure products arrive safely, ready to install.

**Standard Nomenclature**

<b>Manufacturer</b> Gammalux	<b>Cross Section (nom)</b> 4" x 6"	<b>Housing</b> Recessed	<b>Application</b> Techstyle or Echelon	<b>Lamp Type</b> T5 T5HO	<b>Ballast Option</b> ERS Electronic Rapid Start <10% THD DIM Dimming (consult factory)	<b>Voltage</b> 120, 277, UNIV	<b>Run Length</b> Specify continuous runs in total length.**	<b>Mounting Method</b> REC Recessed Mtd.	<b>Shielding</b> ASL Acrylic Satin Lens ASLMD Acrylic Satin Lens, Medium Diffuse* ASLHD Acrylic Satin Lens, Heavy Diffuse*	<b>Options</b> BPE Battery Pack EM. Kit (120V or 227V only) DL UL Damp Label EMERG Emergency ckt. GLR Fuse w/holder 2CKT Dual Circuiting						
<b>GB46RCTE</b>	<b>-</b>	<b>154T5HOST</b>	<b>-</b>	<b>120V</b>	<b>-</b>	<b>ERS</b>	<b>-</b>	<b>4'</b>	<b>-</b>	<b>REC/T1SW</b>	<b>-</b>	<b>ASL</b>	<b>-</b>	<b>WH</b>	<b>-</b>	<b>XX</b>
<b>No. of Lamps</b> 1 or 2	<b>Cross Section Shape</b> Beam	<b>Lamp Configuration</b> Blank Non-Staggered ST add for Staggered Lamp Configuration*	<b>Nominal Lamp Watts</b> 28 (4'-T5) 54 (4'-T5HO)	<b>Ceiling System</b> T1SW 15/16" Flat T Bar Techstyle Ceiling EMSW Echelon Main T EXSW Echelon Cross T	<b>Paint Colors</b> W White (Consult Color Chart for other standard colors) CCM Custom Color Match	<b>Paint Finish</b> H High Gloss SG Semi-Gloss										

\*When Staggering lamps, ASLMD or ASLHD lens is recommended.

\*\* In continuous runs, standard max housing length is 12' unless requested to be longer, up to 24'.



### Construction

**Housing:** Extruded aluminum body 3.75" wide x 6.00" high, 6063T5, 0.070" minimum thickness. Available in one piece, unbroken lengths up to 24'. Runs of fixtures are built to lengths matching exact field conditions.

**Joiner System:** Automatic alignment, no loose parts, one tool to tighten two factory installed bolts for hairline seam. No light leaks. Fixtures that are built for continuous runs and patterns are assembled into a complete pattern and tested for fit and finish at the factory prior to being individually packed and shipped.

**Mounting:** Recessed into Hunter Douglas Contract Techstyle or Echelon ceiling system.

---

### Electrical

**Ballast:** OSRAM SYLVANIA or equal Electronic Rapid Start ballast with less than 10% Total Harmonic Distortion is standard (specify **ERS**). Additional ballast options are available. UL listed wiring and components throughout. Housing wired with quick-connect plugs at all mating joints and individually tested. Max ballast cross section size 1.7" x 1.2". Fixtures that are built for continuous runs and patterns are assembled into a complete pattern and tested with lamps at the factory prior to being individually packed and shipped. All fixtures bear UL & cUL Dry Location labels. Damp Location labels are available (specify **DL** in the options field).

---

### Lamp Stagger

Fluorescent lamps are custom-staggered per exact run length, providing consistent illumination from end to end in each run. Telescoping modules are not acceptable. Factory-engineered drawings indicate the location of each lamp in continuous runs and the dimensioned detail of lamp stagger. Specify **ST** lamp configuration.

---

### Optical Performance

**Reflectors:** Shall be formed diffuse high reflectance aluminum.

**Acrylic Satin Lens:** Shall be 15% DR acrylic snap-in (specify **ASL**).

**Acrylic Satin Lens, Medium Diffuse:** Shall be 15% DR acrylic snap-in (specify **ASLMD**). Multiply efficiency by .93.

**Acrylic Satin Lens, Heavy Diffuse:** Shall be 15% DR acrylic snap-in (specify **ASLHD**). Multiply efficiency by .68.

**Performance:** Independent photometric laboratory testing - ITL or equal - is required. See following photometric information.

---

### Finish

Housing assembly is electrostatically sprayed with high solids aliphatic two component polyurethane to an average thickness of 2 mils. over acid etching primer. High gloss or semi-gloss are standard. Specify **H** for high gloss in Paint Finish field. Specify **SG** for semi-gloss. Consult with factory for other finishes.

---

### Packing and Shipping

Fixtures built for continuous rows and patterns are given a specific location identifier, clearly identified on factory layout drawings provided to installing contractor. Location identifier is printed on the fixture's ID Label, protective wrapping and on each end of fixture carton. Shipping pallets are built with 2" clearance, extending beyond the length and width of cartons, providing shipping protection.

Approximate weight of 4' module is 17 lbs. including carton. Weight of shipping pallet and supplemental packing materials not factored in.

**Photometric / Revit files**

**Fixtures with T5 or T5HO lamping**

(One lamp using Standard Diffuse lens. For Medium and Heavy diffuse lenses, use multiplier on page 2.)

IESNA: LM-63-2002  
ISSUEDATE: 10/12/11  
TEST: GB46RCTS1T5ASL.IES  
TESTLAB: Photopia 3.2.6 see: www.ltiopics.com/ies  
MANUFAC: GAMMALUX LIGHTING SYSTEMS  
LUMCAT: GB44RCTS-1T5HO-ERS-REC-ASL-WH  
LAMP: Fluor. 54W 4' Silhouette T5HO

**Summary Data**

EFFICIENCY (Total): **82.3%**  
EFFICIENCY (Downlight): **82.3%**  
CIE CLASSIFICATION: DIRECT  
LUMENS/LAMP: 5000  
NO. OF LAMPS: 1  
LUMINOUS OPENING: RECTANGULAR  
Width: 0.29 (Feet)  
Length: 3.83  
Height: 0.18  
INPUT WATTS: 59

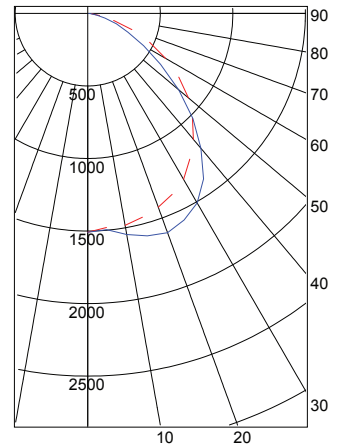
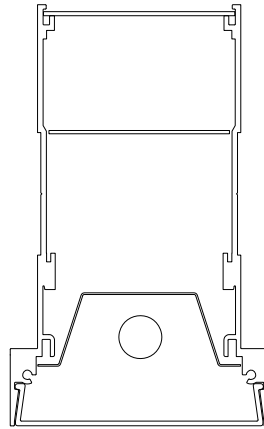

Quadralaterally Symmetric  
Dashed: 0 Degrees Solid: 90 Degrees

**Fixtures with T5 or T5HO lamping**

(Two lamp using Standard Diffuse lens. For Medium and Heavy diffuse lenses, use multiplier on page 2.)

IESNA: LM-63-2002  
ISSUEDATE: 10/12/11  
TEST: GB46RCTS2T5ASL.IES  
TESTLAB: Photopia 3.2.6 see: www.ltiopics.com/ies  
MANUFAC: GAMMALUX LIGHTING SYSTEMS  
LUMCAT: GB44RCTS-2T5HO-ERS-REC-ASL-WH  
LAMP: Fluor. 54W 4' Silhouette T5 HO

**Summary Data**

EFFICIENCY (Total): **72.1%**  
EFFICIENCY (Downlight): **72.1%**  
CIE CLASSIFICATION: DIRECT  
LUMENS/LAMP: 5000  
NO. OF LAMPS: 2  
LUMINOUS OPENING: RECTANGULAR  
Width: 0.29 (Feet)  
Length: 3.83  
Height: 0.18  
INPUT WATTS: 118

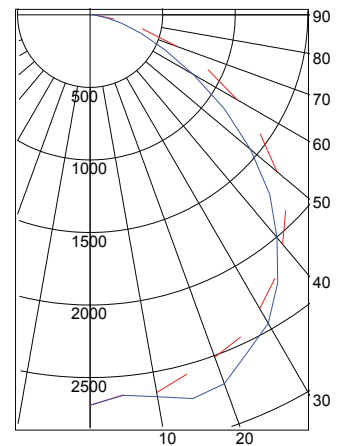
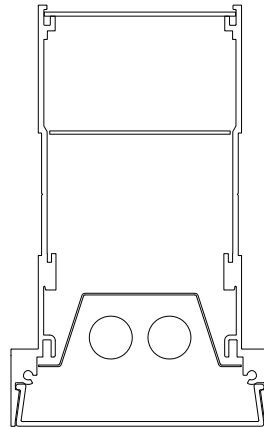

Quadralaterally Symmetric  
Dashed: 0 Degrees Solid: 90 Degrees



Acrylic Satin Lens (ASL)      Acrylic Satin Lens, Medium Diffuse (ASLMD)      Acrylic Satin Lens, Heavy Diffuse (ASLHD)

**15/16" T Bar - 1 11/16":**  
Specify **T1SW** code in catalog #

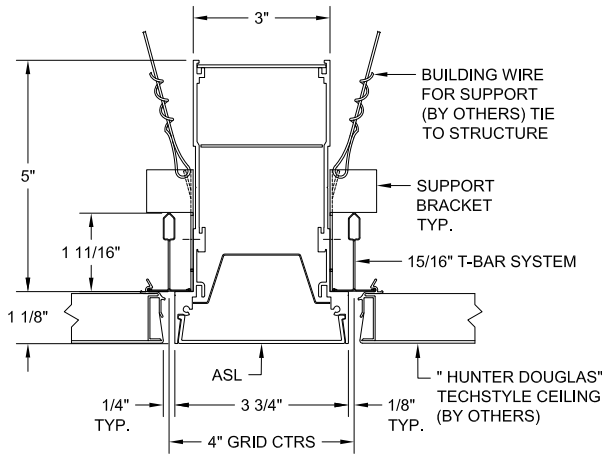

**15/16" T Bar - 1 1/2":**  
Specify **T1SW** code in catalog #

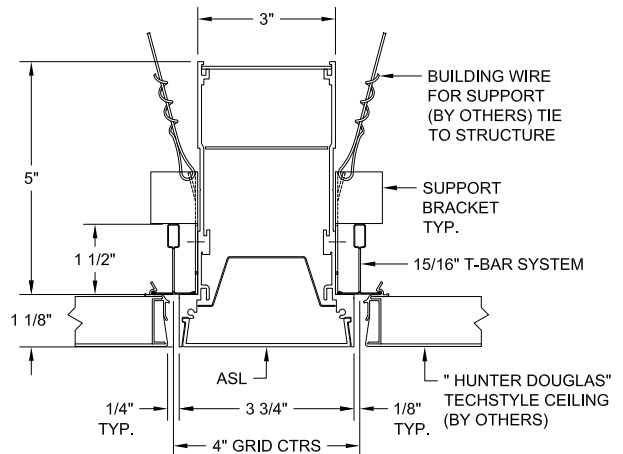

**Echelon Main T Bar:**  
Specify **EMSW** code in catalog #

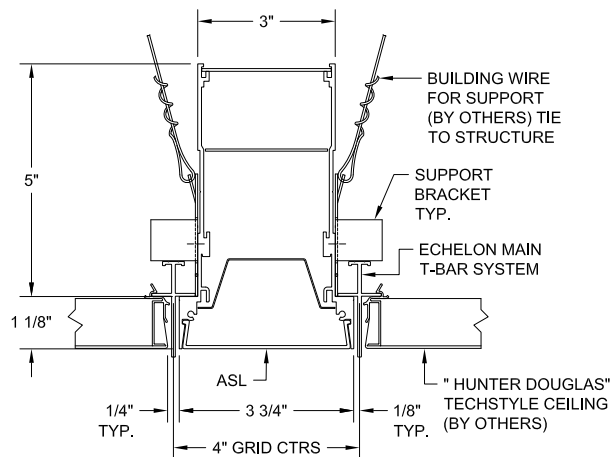

**Echelon Cross T Bar:**  
Specify **EXSW** code in catalog #

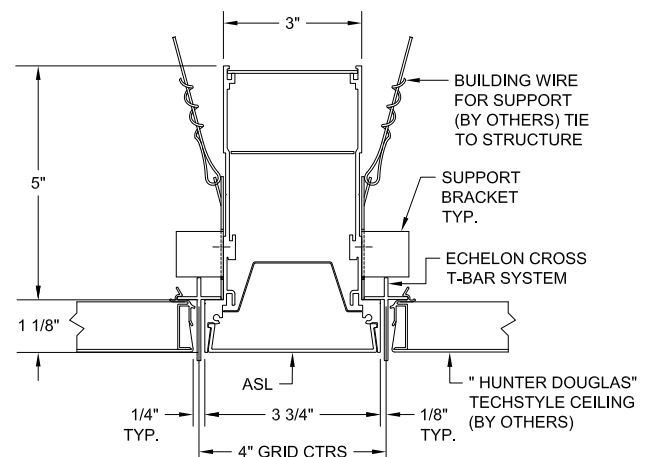

**Mounting bracket is field adjustable to accommodate all four conditions.**

**Gammalux Lighting Systems reserves the right to change details of fixture design and construction at any time.**

**Standard Colors / Finishes**

**Due to variances in computer monitors and color printers, this page should be used for general reference only.  
For a sheet of physical color samples, please consult factory.**

**High Gloss Finish**

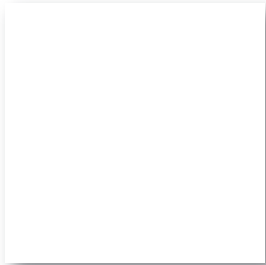

White (WH)



Red (RH)



Yellow (YH)



Green (GH)



Blue (BH)



Black (BKH)

**Semi Gloss Finish**

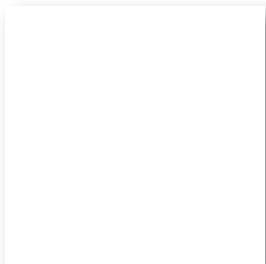

White (WSG)



Silver (SSG)



Gray (GYSG)

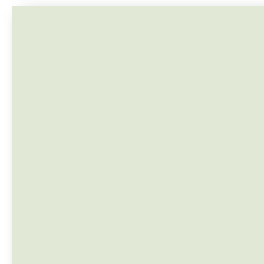

Off White (OWSG)

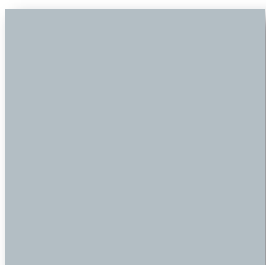

Light Gray (LGYSG)

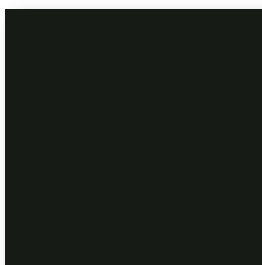

Bronze (BZSG)



Satin Aluminum (SAPSG)

**Due to variances in computer monitors and color printers, this page should be used for general reference only.  
For a sheet of physical color samples, please consult factory.**